

Atlas Application Guide 108

Coating Surface Temperature
During Accelerated UV Test Methods
and Selection Criteria for
Encapsulants of Photovoltaic Modules

Atlas Material Testing Technology

Atlas SunSpots, Volume 38, Issue 83, Fall, 2008



Coating Surface Temperature During Accelerated UV Test Methods and Selection Criteria for Encapsulants of Photovoltaic Modules

By Michael D. Kempe, National Renewable Energy Laboratory

Originally published in Atlas SunSpots, Volume 38, Issue 83, Fall, 2008.

Abstract

Photovoltaic modules are exposed to extremely harsh conditions of heat, humidity, high voltage, mechanical stress, thermal cycling, and ultraviolet (UV) radiation. The current qualification tests (e.g., IEC 61215) do not require UV exposure high enough to evaluate a lifespan of 20 years or more. Methods to quickly test the UV durability of photovoltaic materials are needed. The initial performance and material cost of encapsulant materials must be taken into account, but equally important is their ability to maintain adhesion and transmissivity under UV exposure.

This can be evaluated under highly accelerated conditions with light from a xenon arc lamp using glass that transmits more UV radiation than standard cerium doped glass. The use of highly transmissive glass results in a UV dose that is about 3.8 times higher with regard to adhesion. With this configuration the effect of 20 years of exposure can be obtained in just over 6 months using standard commercial accelerated stress chambers.

Introduction

Polymeric encapsulant materials are used in photovoltaic (PV) modules to provide electrical insulation, protect modules from mechanical damage and environmental corrosion, and to optically couple the PV cells to the front-sheet material. PV module qualification tests (such as IEC 61215) are designed to provide minimum standards for module durability and to demonstrate a degree of safety in the use of modules in the production of electricity. The specific effects of these highly accelerated stress tests vary significantly from manufacturer to manufacturer and even more so among different PV technologies. These tests alone do not necessarily predict the long-term stability of a module design.

Because of the extreme difficulty of exposing production modules to concentrated light sources for long periods of time, the UV exposure required by qualification tests corresponds to a timescale of a few months rather than years. The IEC qualification tests 61215, 61646, and 61730-2 [1, 2, 3] include a "UV Preconditioning Test." Here modules are held at $60\text{ }^{\circ}\text{C} \pm 5\text{ }^{\circ}\text{C}$ and subjected to 15 kWh/m^2 between 280 nm and 385 nm with at least 5 kWh/m^2 between 280 nm and 320 nm. For comparison, the AM 1.5 spectrum [4] contains 35.3 W/m^2 and 1.52 W/m^2 in these ranges, respectively. To achieve the necessary irradiance for the IEC tests using the AM 1.5 spectrum, it would take 17.7 days for the 280 nm to 385 nm range and 137 days for the 280 to 320 nm range. Considering that AM 1.5 has a total of 1000 W/m^2 and that a more typical outdoor day/night average is about 250 W/m^2 , another factor of 4 is

necessary to compare chamber exposure to outdoor exposure [5]. Even with this, the equivalent exposure time is still only 71 days for 280 nm to 385 nm and 548 days for the 280 nm to 320 nm range. Similarly, IEC 62108 requires a “UV Conditioning Test” consisting of 50 kWh/m² below 400 nm. This is equivalent to 45 days of AM 1.5 or about 181 days outdoors. Thus, these tests do not provide assurance that a PV module will withstand 20 or more years of UV radiation. These tests are only designed to provide minimum standards for PV panel construction.

Obtaining a 20-year UV dose on a full-size module would be expensive and time consuming. Alternatively, one can evaluate small samples of materials and/or minimodules constructed in a similar manner to a full-size module. A method for evaluating the UV stability of PV packaging materials in a relatively short timeframe is necessary to evaluate module reliability. This work discusses methods for quickly evaluating the potential use of polymeric encapsulants in PV modules, including initial screening protocols looking at light transmission and encapsulant cost.

Experimental

UV exposure (60°C/60% RH and 2.5 UV suns) was obtained using an Atlas Ci4000 Weather-Ometer® with a light intensity of 114 W/m² between 300 and 400 nm. The Xenon arc lamp light was filtered using a type “S” borosilicate inner and outer filter. The black panel standard temperature was maintained at 100°C ± 7°C, resulting in a temperature of 70°C to 80°C for the transparent glass lap shear samples.

Lap shear tests were conducted as outlined previously by Kempe et. al [6] using an Instron Test Unit (model 1122/5500R). Two ¼"-thick 3" × 3" [6.35 x 76.2 x 76.2 mm] glass pieces were used for the test specimens. The adhesive was applied to an approximately 19-mm² area at a thickness of about 0.5 mm (see Figure 1).

The effective solar photon-weighted absorptivity of polymeric encapsulant materials (integrated between λ=200 nm and 1100 nm) was measured by curing thick sections (1.5 to 5.5 mm) of polymer between two pieces of 3.18-mm thick AFG Krystal Klear glass and measuring the transmission using a Lambda 9 UV-Vis spectrophotometer equipped with an integrating sphere. Percent transmission is relative to the product of the AM 1.5 [4] irradiance in units of W/m²/nm multiplied by the wavelength to yield values related to the photon density. If one neglects reflection at the polymer glass interfaces, assumes highly transmissive materials, the total transmission can be estimated as

$$T = T_{glass} e^{-(t_p \alpha_p)}$$

Equation 1.

Here $T_{glass} = 88.94\%$ and is the solar photon weighted transmission through a piece of 6.35 mm-thick plate glass. t_p is the polymer layer thickness, and α_p is the solar weighted photon absorptivity in the polymer.

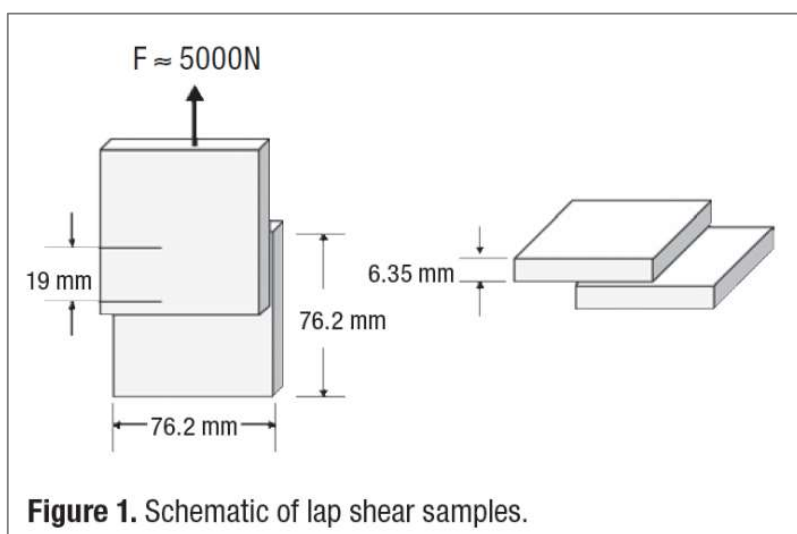

Figure 1. Schematic of lap shear samples.

Results and Discussion

Encapsulant materials used on the front side of a PV device must provide good optical coupling for the maximum transmission of incident photons. A large number of materials were evaluated, and the AM 1.5 solar weighted absorptivity was determined (Table 1). The total transmission to a hypothetical cell through a 3.18-mm piece of glass and through 0.45 mm of encapsulant was estimated as:

$$T_{cell} = \frac{(100 + T_{glass})}{2} e^{-(t_p \alpha_p)} \quad \text{Equation 2.}$$

Here $T_{glass} = 88.94\%$ and is the global solar weighted photon transmission through a piece of glass two times as thick. Equation 2 slightly overestimates the light because T_{glass} includes light from multiple reflections; however, the

Encapsulant	AM 1.5 Solar Weighted Absorptivity 200 nm to 1100 nm (1/mm)	Transmission to Cells through 3.18 mm glass and 0.45 mm Encapsulant (%)	Approximate Cost Relative to EVA	Comments
GE RTV615	0.000 ± 0.003	94.5 ± 0.3	4.45	PDMS Addition Cure
Dow Corning Sylgard 184	0.001 ± 0.004	94.4 ± 0.3	6.97	PDMS Addition Cure
Dow Corning 527	0.001 ± 0.003	94.4 ± 0.3	2.33	PDMS Gel Addition Cure
Polyvinyl Butraldehyde	0.014 ± 0.005	93.9 ± 0.4	1.50	
EVA	0.014 ± 0.005	93.9 ± 0.4	1.00	
NREL Experimental	0.025 ± 0.006	93.4 ± 0.4	1.28	
Thermoplastic Polyurethane	0.027 ± 0.004	93.3 ± 0.3	2.00	
Thermoplastic Ionomer #1	0.052 ± 0.007	92.3 ± 0.4	1.00	Co-polymer of Ethylene and Methacrylic Acid
DC700	0.067 ± 0.004	91.7 ± 0.3	0.94	PDMS Acetic Acid Condensation Cure
Theroplastic Ionomer #2	0.147 ± 0.007	88.4 ± 0.4	2.00	Co-polymer of Ethylene and Methacrylic Acid

cell-to-polymer interface will also cause multiple reflections, so the net result should still provide a good estimate. The light that reaches the cell will then be absorbed by the cell as governed by the cell optics.

According to Equation 2, a perfectly transparent encapsulant would transmit about 94.5% of the photons between 200 nm and 1100 nm. Because of the thinness of the encapsulant layer, the absorption and scattering in ethylene vinyl acetate (EVA) only account for about a 0.6 ± 0.2% loss in the potential initial power output of a module.

EVA will yellow somewhat after environmental

Table 1: AM 1.5 [4] Solar photon weighted optical density determined from transmission measurements through polymer samples of various thickness (1 to 5 mm) sandwiched between two pieces of 3.18 mm-thick Krystal Klear glass. Only the solar spectrum below 1100 nm was used for transmission measurements. The approximate cost factor relative to EVA is based on costs quoted by the manufacturer where no effort was made to negotiate a better price. The true cost factor could easily be different by a factor of two.

exposure. The optical transmission of thin aged encapsulant samples were obtained as an estimate of the yellowing potential of these encapsulants. Following the same procedures for calculating Table 1, light transmission measurements were made of UV-aged polymer samples behind glass. It was estimated that 0.45 mm-thick sections of EVA and GE RTV 615 placed behind 3.18 mm Krystal Klear glass would transmit 88.7 ± 2% and 93.6 ± 2% after being exposed to 14,364 h and 15,238 h respectively of 60 °C/60% RH/2.5 UV suns. The small 0.9% transmission loss for GE RTV 615 is principally due to minor etching and corrosion of the glass.

For a 15% efficient module, this 4.9% transmission difference between EVA and RTV615 would result in a 7.4W loss. Because this exposure has a far greater UV dose than would be experienced over an expected module lifetime, this should be considered an upper limit for lost irradiance. Taking a lifetime average transmission loss difference of $7.4/2 = 3.7 \text{ Wp/m}^2$, in addition to the initial 0.5 Wp/m^2 , as a time average power loss for using EVA instead of a silicone, one would expect an additional 4.2 Wp/m^2 performance loss. The monetary value of 4.2 Wp/m^2 gives an upper limit to the additional cost that might be acceptable for a better performing encapsulant. EVA is the dominant encapsulant used in the PV industry not because it is the best material but because the performance gain from using other encapsulants is not very large. While this higher transmission alone probably does not justify the additional expense of silicones, it may justify the additional cost of better EVA formulations and/or other alternative resins.

Lap shear samples of EVA were made using low Fe glass both with (6.35 mm thick Krystal Klear) and without Cerium (1990s vintage 5.61 mm-thick PPG Starphire [7]) to evaluate the effect of enhanced UV transmission on the adhesion of EVA [8, 9, 10]. The transmission of UV light through some sample glasses is shown in Figure 1 before and after solarization at 2.5 UV suns in an Atlas Ci4000 Weather-Ometer® [11] (see Figure 2). The UV-B region extends from 290 to 320 nm and is the region of the solar spectrum typically causing the most damage to hydrocarbon-based polymeric materials. Here we see that the addition of minute amounts of Ce to the glass dramatically reduces the transmission of UV-B radiation and that solarization of the glass extends this absorption to even longer wavelengths.

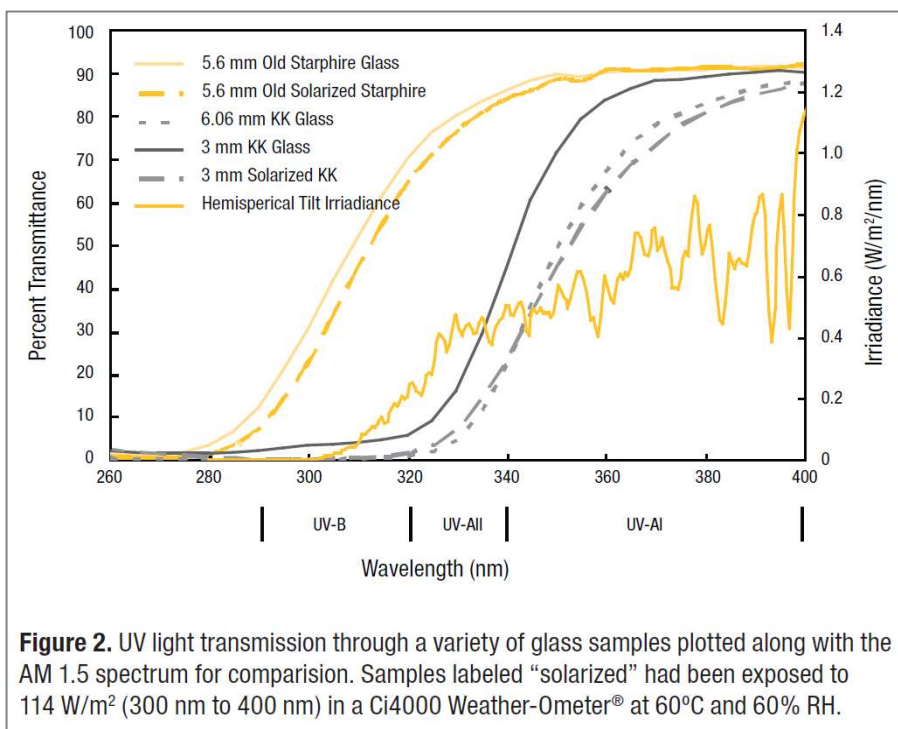

The effect of increased UV-B transmission on the adhesion of EVA was evaluated using glass lap shear samples exposed to 2.5 UV suns. The fit lines in Figure 3 are exponential decay curves offset from each other on the time axis by a factor of 8. This fit is empirical in nature and valid only for the initial changes in adhesion. The degradation of adhesion for the Ce-doped glass initially dropped to values between 2 MPa and 4 MPa, where it remained for about 10,000 h. Once the adhesive strength began to drop, failure was typically around 80% to 90% on the side facing the UV lamp, indicating that the UV light was responsible for the loss in adhesion.

When EVA is formulated for use in PV applications, a UV absorber is added to reduce degradation. Exposure to UV radiation causes deadhesion preferentially on the side facing the light source because this interface receives a full dose of the light transmitted through the glass. For the lap shear samples in this work, the refractive index difference between the glass and the polymer is small, so the reflection at this interface is negligible. Therefore, the amount of UV radiation reaching this interface, $I(\lambda)$, is equal to the lamp irradiance, I_{Lamp} , reduced by reflection

at the glass-to-air interface and by the absorption from a single pass through the glass to the polymer/glass interface:

$$I(\lambda) + I_{Lamp} \frac{(n_1 - n_2)^2 + k^2}{(n_1 + n_2)^2 + k^2} e^{-\frac{4k}{\lambda}t} \quad \text{Equation 3.}$$

Values for AM 1.5 were used as an approximation for I_{Lamp} because the Weather-Ometer was set up to duplicate natural sunlight. According to Rubin [12], the real component of the refractive index for typical soda lime glasses can be approximated within $\pm 1\%$ by

$$n = 1.5130 - 0.003169\lambda^2 + \frac{0.003962}{\lambda^2} \quad \text{Equation 4.}$$

With these estimates for n and the transmission of light through a sheet of glass, after solarization, values for k were estimated on a wavelength by wavelength (solved numerically using Excel™) and accounting for multiple reflections. From this, the irradiance at the glass- to-polymer interface (see Figure 4) of the lap shear samples using the different glasses was estimated using Equation 3.

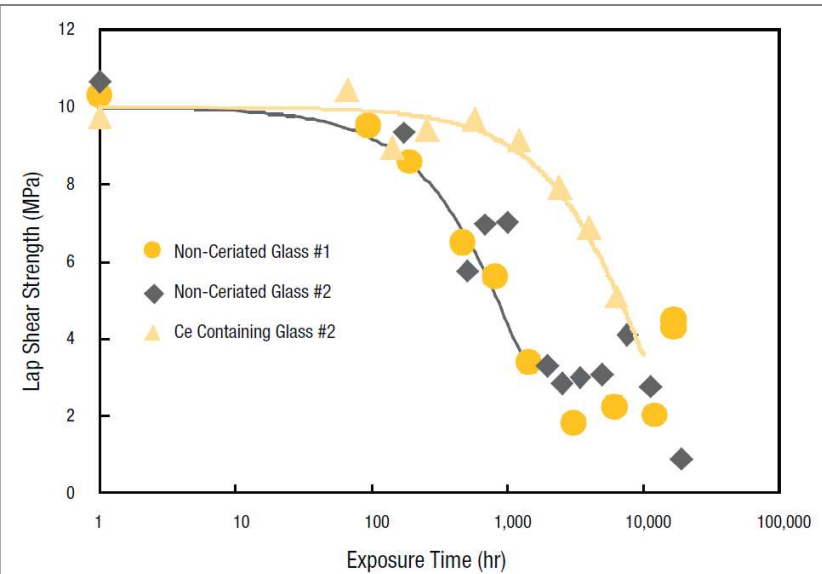

Figure 3: Lap shear strength of EVA after exposure to 60 °C/60% RH/2.5 UV suns.

An action spectrum describes the effectiveness of incoming photons (as a function of wavelength) for producing a specified type of damage. For exposure to a specific distribution of photons, $I(\lambda)$, the activation spectrum describes the relative degradation rate as a function of wavelength. The activation spectrum is thus the result of weighting the action spectrum against a specific wavelength distribution of photons. Unless there are specific absorption bands in the region of interest, the action spectrum of the incoming photons typically varies exponentially [13, 14] with wavelength ($\sim e^{-B\lambda}$). With this approximation the activation spectrum $[E(\lambda)]$ is given by

$$E(\lambda) \sim I(\lambda)\lambda e^{-B\lambda} \quad \text{Equation 5.}$$

and the effective UV dose (D) can be estimated as:

$$D \sim \int I(\lambda)\lambda e^{-B\lambda} d\lambda \quad \text{Equation 6.}$$

where $I(\lambda)$ is the radiant energy in ($W/m^2/nm$), λ is the wavelength, and B is an empirical constant quantifying the wavelength sensitivity. The effective dose, D , describes the degradation caused by exposure to a polychromatic light source, $I(\lambda)$.

In the Weather-Ometer®, the heat load on the different lap shear samples would be expected to be nearly identical, so temperature differences would not explain the accelerated loss of adhesion. For the ceriated and non-ceriated glass used in the various lap shear samples, the effective dose, D , should differ by a factor of 8. Numerical solution of Equation 6 results in an estimate of the wavelength sensitivity of $B = 0.07$ ($1/nm$). From this, the activation spectrum for adhesion loss was estimated for a number of front-sheet materials. Using 3.18 mm-thick low Fe, ceriated AFG Krystal Klear as a standard for light transmission, the effective dose acceleration factors were calculated (see Figure 5).

The use of an exponential action spectrum has empirical significance, but in the absence of rigorous evaluation, it is only a first-order estimate. The effect of different action spectra was evaluated to determine the sensitivity to this assumption and to determine the potential range of possible acceleration factors. A linear action spectrum was estimated and the cut-on wavelength λ_o was adjusted so that the ratio of effective dose for the Ce and non-Ce glass lap shear samples would be 8 (see Figure 6).

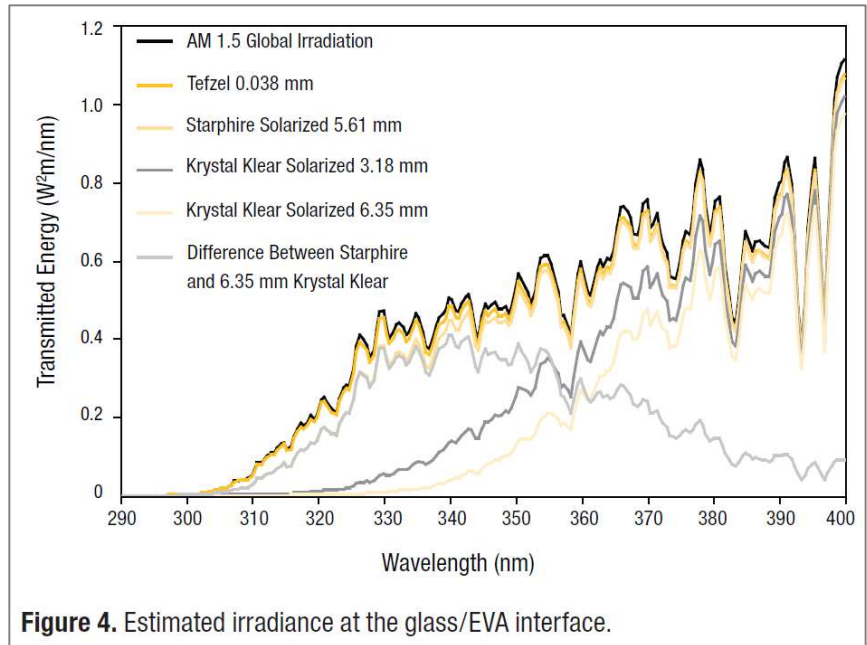

Figure 4. Estimated irradiance at the glass/EVA interface.

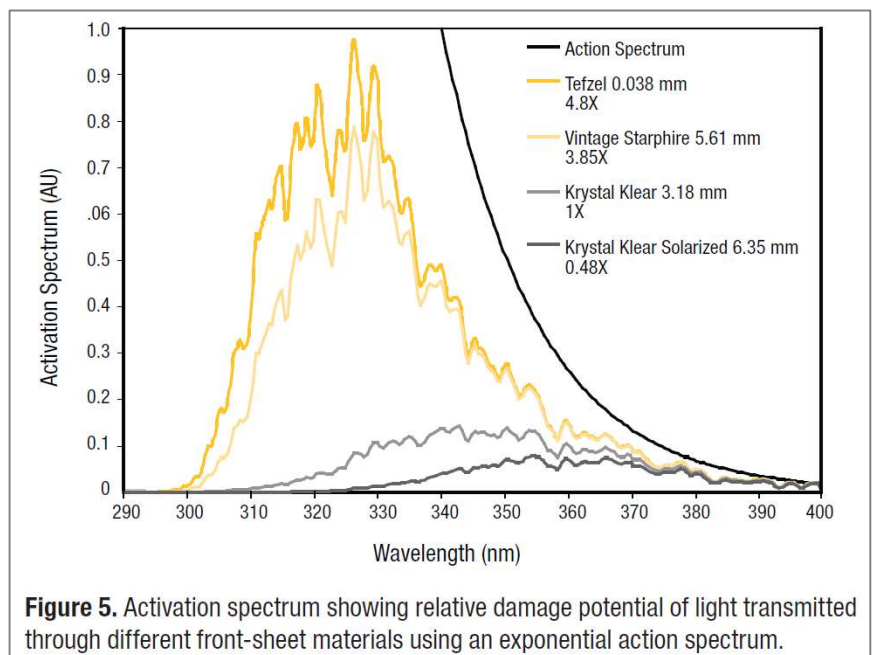

Figure 5. Activation spectrum showing relative damage potential of light transmitted through different front-sheet materials using an exponential action spectrum.

Using $\lambda_o = 368$ nm, the activation spectra for different front-sheets were calculated and the acceleration factors relative to 3.18 mm-thick Krystal Klear glass were evaluated. A similar analysis was conducted using a step function action spectrum yielding $\lambda_o = 354$.

Although significantly varying action spectra were used, the UV dose acceleration factors did not vary dramatically (see Table 2). The data for the step function were the most different, but it is clear that this result is far from the true action spectrum. Because the differences in the transmission of the various glasses differ the most at shorter

Action Spectrum		Exponential	Linear	Step
		B = 0.07 (1/nm)	$\lambda_0 = 354$ (nm)	$\lambda_0 = 368$ (nm)
Tefzel	0.036 mm	4.83	4.30	3.63
Vintage Starphire	5.61 mm	3.85	3.40	3.19
Krystal Klear	3.18 mm	1	1	1
Krystal Klear	6.35 mm	0.48	0.43	0.40

Table 2. Approximate UV dose acceleration factors for different front-sheets.

wavelengths, action spectra that emphasize this region (exponential function) yield higher acceleration factors than those that emphasize lower wavelengths. Thus, the exponential action

spectrum can be regarded as an upper limit. The true acceleration factors are likely to reside somewhere between the linear results and the exponential function results.

Using 3.18 mm Krystal Klear glass as a reference, the low-Fe, non-ceriated PPG Starphire glass transmits UV light that is estimated to cause delamination 3.85 times faster. The environmental chamber irradiates the samples with 2.5 times as much UV radiation as the standard AM 1.5 spectrum. The Weather-Ometer® runs 24 hrs a day this gives a further UV dose acceleration of approximately 4 for a non-tracking system [5]. This yields a total acceleration factor of $3.85 \times 2.5 \times 4 = 38.5$. Therefore, to get a UV dose equivalent to 20 years of exposure, 6.2 to 7 months of exposure is needed in the Weather-Ometer. Without the use of this highly transmissive glass it would take 2 years to get a UV dose equivalent to 20 years.

Conclusions

Materials used for PV encapsulation must be evaluated for their ability to transmit light and to maintain mechanical integrity for extended periods of time under long-term UV exposure. A survey of candidate encapsulants has indicated that, although absorptivity can vary greatly, the use of thin encapsulant layers makes absorption differences of secondary importance. Similarly, the effects of severe degradation have only a minor effect on light transmission. Current qualification standards do not adequately evaluate the effects of UV radiation, requiring additional tests if one wants to be confident in the longevity of PV modules. Exposure of PV materials to UV radiation in an environmental chamber using highly UV transmissive glass allows UV doses equivalent to 20 years of exposure (as compared to stress behind 3.18 mm-thick Ce-doped glass) in about 6 months. This allows reasonable evaluation of PV materials. Highly accelerated stress tests like this are necessary to evaluate the effect of UV radiation on module performance. This also highlights the potential risks of using non-Ce doped glass in PV applications.

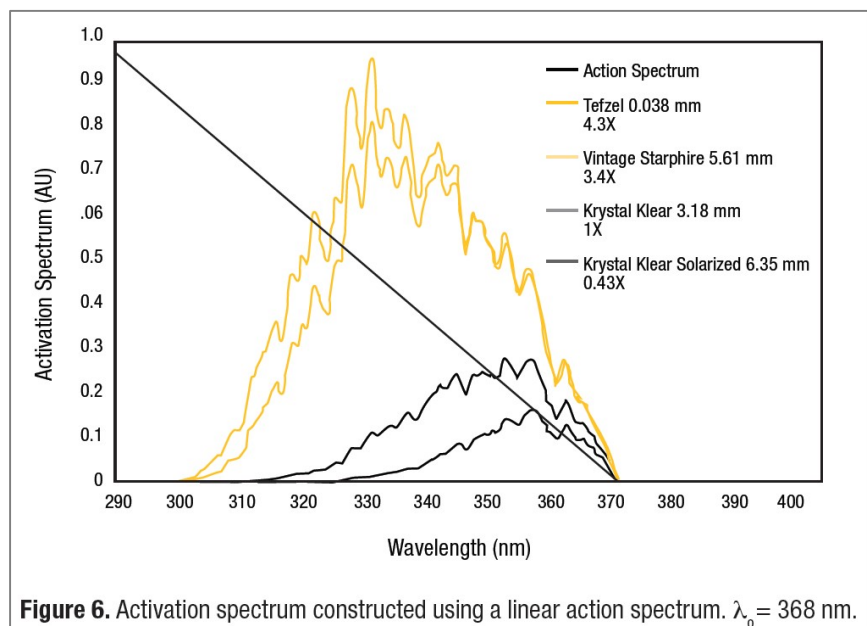

Figure 6. Activation spectrum constructed using a linear action spectrum. $\lambda_0 = 368$ nm.

Acknowledgment

This work was carried out under U.S. Department of Energy contract number DE-AC36 -99G010337.

References

- [1] IEC 61215, Crystalline Silicon Terrestrial Photovoltaic (PV) Modules – Design Qualification and Type Approval
- [2] IEC 61646, Thin-Film Terrestrial Photovoltaic Modules – Design Qualification and Type Approval
- [3] IEC 62108, Concentrator Photovoltaic (CPV) Modules and Assemblies – Design Qualification and Type Approval
- [4] ASTM G 173-03, “Standard Tables for Reference Solar Spectral Irradiances: Direct Normal and Hemispherical on 37o Tilted Surface”
- [5] L. M. Moore, H. N. Post, “Five Years of Operating Experience at a Large Utility-Scale Photovoltaic Generating Plant,” Prog. Photovolt: Res. Appl. 16, 249-259 (2008)
- [6] M.D. Kempe, G.J. Jorgensen, K.M. Terwilliger, T.J. McMahon, C.E. Kennedy, T.T. Borek, “Acetic Acid Production and Glass Transitions Concerns with Ethylene-Vinyl Acetate used in Photovoltaic Devices,” Solar Energy Materials & Solar Cells, 91, 315-329 (2007)
- [7] D. L. King, M. A. Quintana, J. A. Kratochvil, D. E. Ellibee, B. R. Hansen, Prog. Photovolt. Res. Appl. “Photovoltaic Module Performance and Durability Following Long-Term Field Exposure,” 8, 241-256 (2000)
- [8] A. Torikai, H. Hasegawa, “Wavelength Effect on the Accelerated Photodegradation of Polymethylmethacrylate,” Polymer Degradation and Stability 61, 361-364 (1998)
- [9] H. Xingzhou, “Wavelength Sensitivity of Photo-Oxidation of Polyethylene,” Polymer Degradation and Stability, 55, 131-134 (1997)
- [10] X. Hu, “Wavelength Sensitivity of Photo-Oxidation of Polyamide 6,” Polymer Degradation and Stability 62, 599-601 (1998)
- [11] D. E. King, F. J. Pern, J. R. Pitts, C. E. Bingham, A. W. Czanderna, “Optical Changes in Cerium-Containing Glass as a Result of Accelerated Exposure Testing,” 26th IEEE PVSC, Sept 29-Oct 3, Anaheim, California (1997)
- [12] M. Rubin, “Optical Properties of Soda Lime Silica Glasses,” Solar Energy Materials 12, 275-288 (1985)
- [13] A. L. Andrad, “Wavelength Sensitivity in Polymer Photodegradation,” Advances in Polymer Science 128, 49-94 (1997)
- [14] A. L. Andrad, S. H. Hamid, X. Hu, A. Torikai, “Effects of Increased Solar Ultraviolet Radiation on Materials,” Journal of Photochemistry and Photobiology B: Biology 46, 96-103 (1998)

Author: Michael D. Kempe, National Renewable Energy Laboratory, 1617 Cole Blvd., Golden, CO 80401

© 2008 IEEE. Reprinted, with permission, from 33rd IEEE Photovoltaics Specialists Conference, San Diego

Originally published in Atlas SunSpots, Volume 38, Issue 83, Fall, 2008

Atlas Material Testing Technology | 1500 Bishop Court | Mount Prospect, Illinois 60056, USA
www.atlas-mts.com

© 2022 Atlas Material Testing Technology LLC. All Rights Reserved. ATLAS and ATLAS logo are registered trademarks of Atlas MTT LLC. AMETEK logo is registered trademark of AMETEK, Inc.